

CE2500 CASE ERECTOR

The **CE2500** is a versatile, small footprint machine offering excellent value for money.

- Up to 25 cases/minute
- **Allen Bradley PLC with HMI**
- Less than 3 minute tool-less changeover
- 96" x 44" Footprint
- Vertical Magazine capacity for approx.80 – 100 "C" Flute Cases stacked horizontally (29 ECT minimum 175#)
- Positive vacuum 2-side case erection
- Low level magazine alert system with single red stack light
- Case erection jam detection and automated shut-down
- Rugged construction – 2" x 2" welded tube frame
- Mild steel construction, powder coated paint
- 2" Tape head
- Casters for portability
- Full interlocked guarding
- One operator / maintenance manual
- UL/CSA Approved components

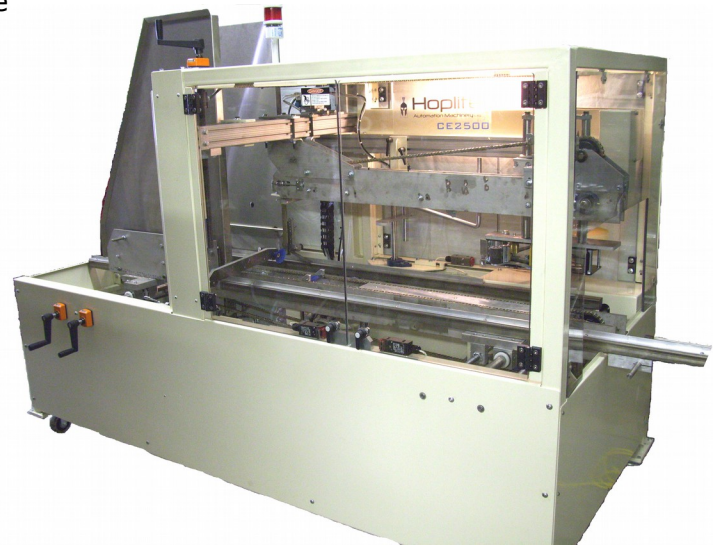

Erector Options

- Full stainless steel construction
- Partial stainless steel construction
- Electrical (480/3/60)
- Left or right hand operation
- Hot melt bottom sealing
- Pre-start Health and Safety Review

Standard Utilities

- 220/3/60 Electrics
- 7 cfm @ 80 psi



CASE RANGE (inches)

Knock-down Length	32
Box Length	6 - 22
Box Width	5.5 - 14
Box Depth	4.5 - 18
Box Height(body + 1 flap)	20



67 Victoria Str E PO Box 10074 Alliston, Ontario Canada L9R 0B7

Tel: 705-999-3755

www.hoplite-ltd.com

Hoplite Automation Machinery LTD.

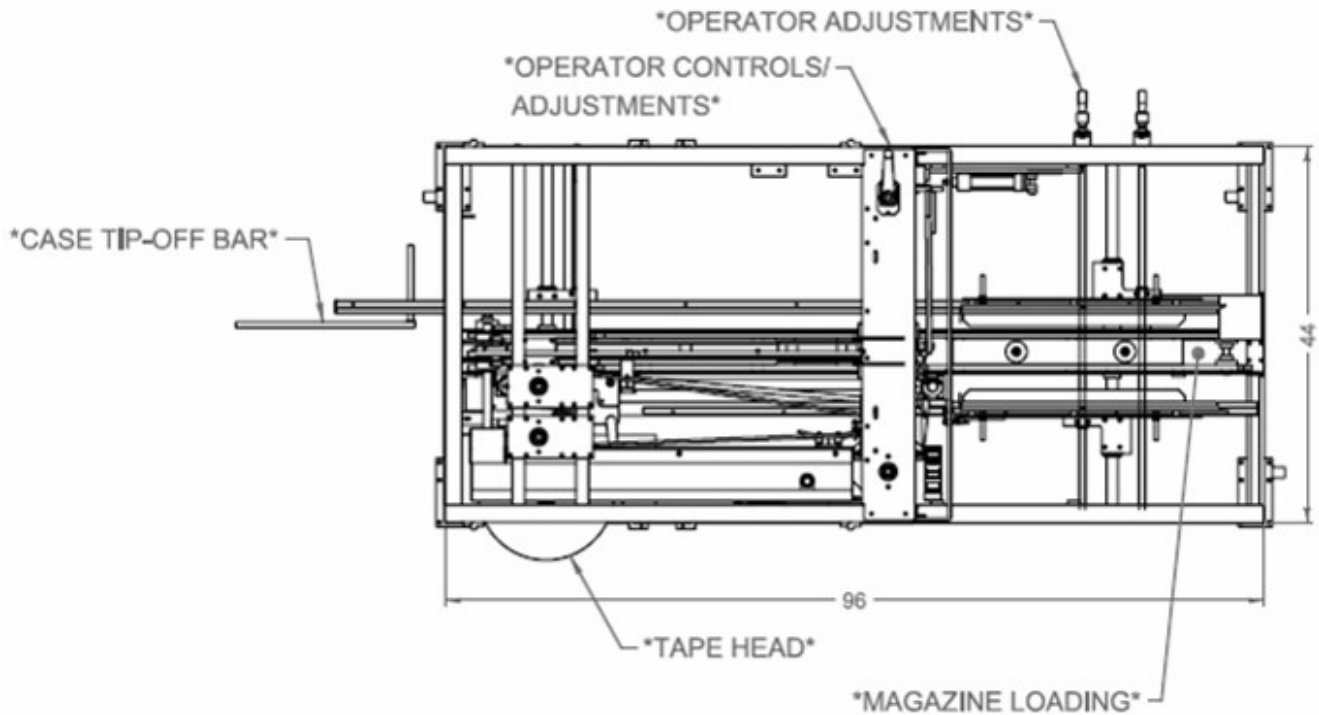
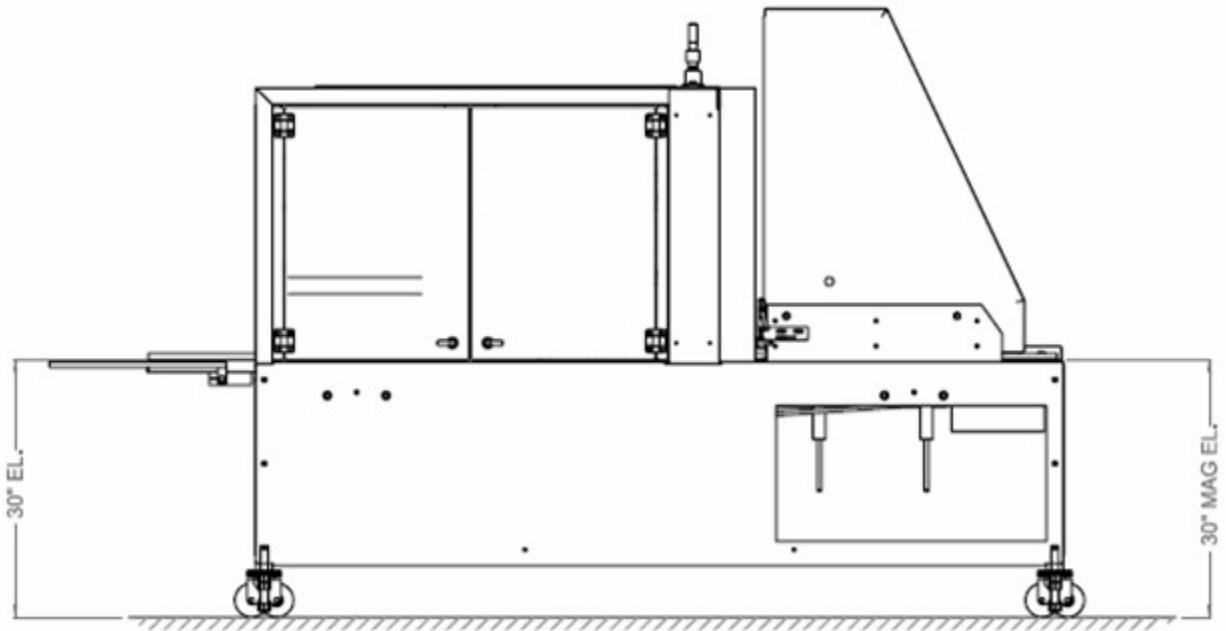

67 Victoria Str E PO Box 10074 Alliston, Ontario Canada L9R 0B7
Tel: 705-999-3755
www.hoplite-ltd.com